

Introduction to Computer Graphics

Farhana Bandukwala, PhD

Lecture 10: Projections

Outline

- Viewing 3D world on 2D displays
- Perspective projection
- Parallel projection
- Cameras and clipping planes

Viewing 3D World on 2D plane

- To view 3D, need to project points onto 2D view plane
- Scene or view volume
- Window: projection plane
- Viewport: display plane
- Projection: intersection of projectors w/window
- Center of projection: focal point for all projectors

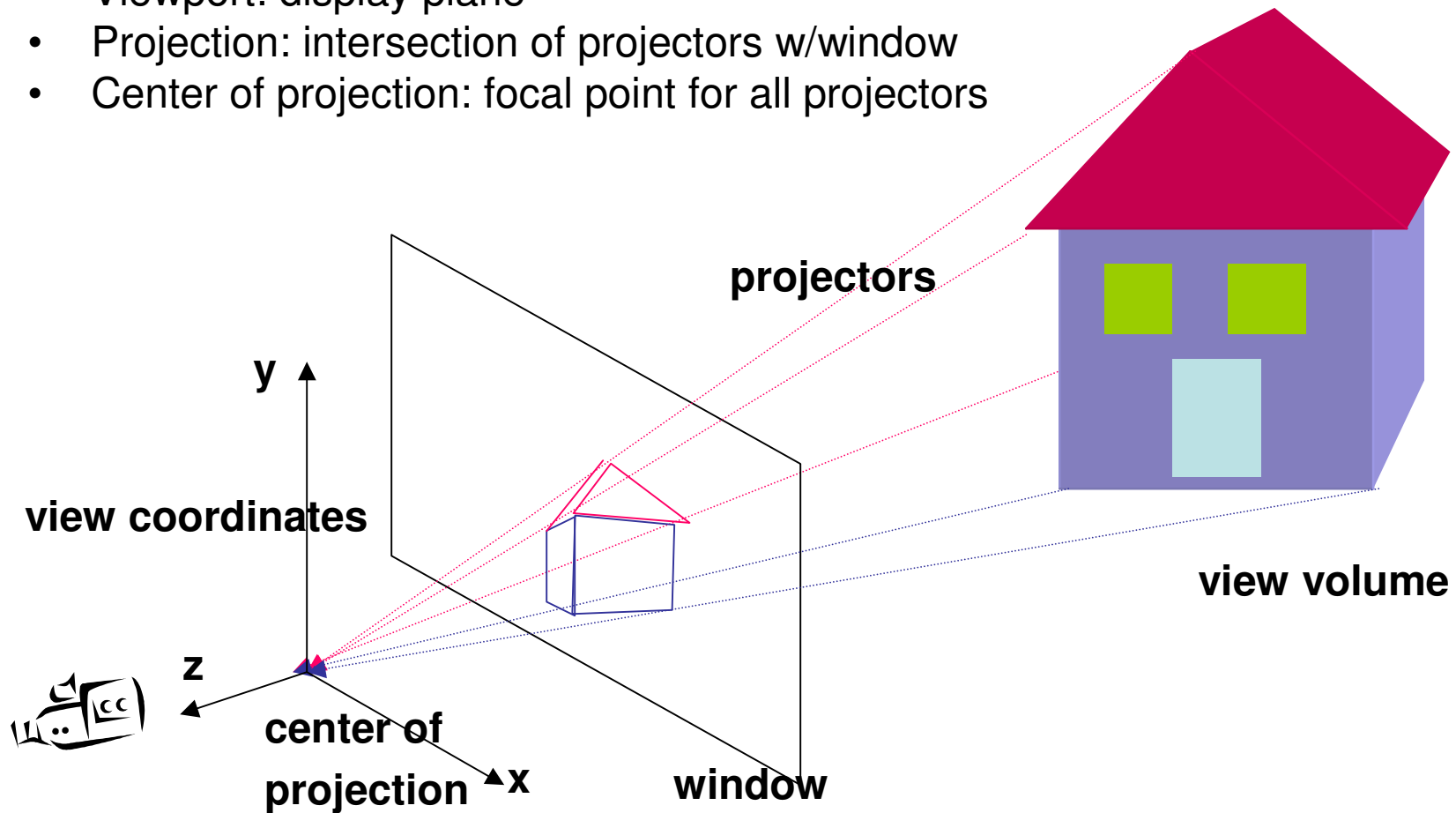

Terminology

- Projection plane = view plane
 - Defined by view reference point (VRP) in world coordinates and view-plane normal (VPN)
- Viewing reference coordinate (VRC) system defined on view plane with VRP as origin
 - VPN is one axis, view-up vector (VUP) is another, and third is perpendicular to plane containing the VUP & VPN
- Window: defines extents on view plane that are within display's viewport using VRC
 - Center of window (CW) not necessarily at VRP
- Center of projection (COP) specified in VRC
 - COP does not change with respect to VRP even if view plane is moved in the world coordinate system

Diagram of view plane terms

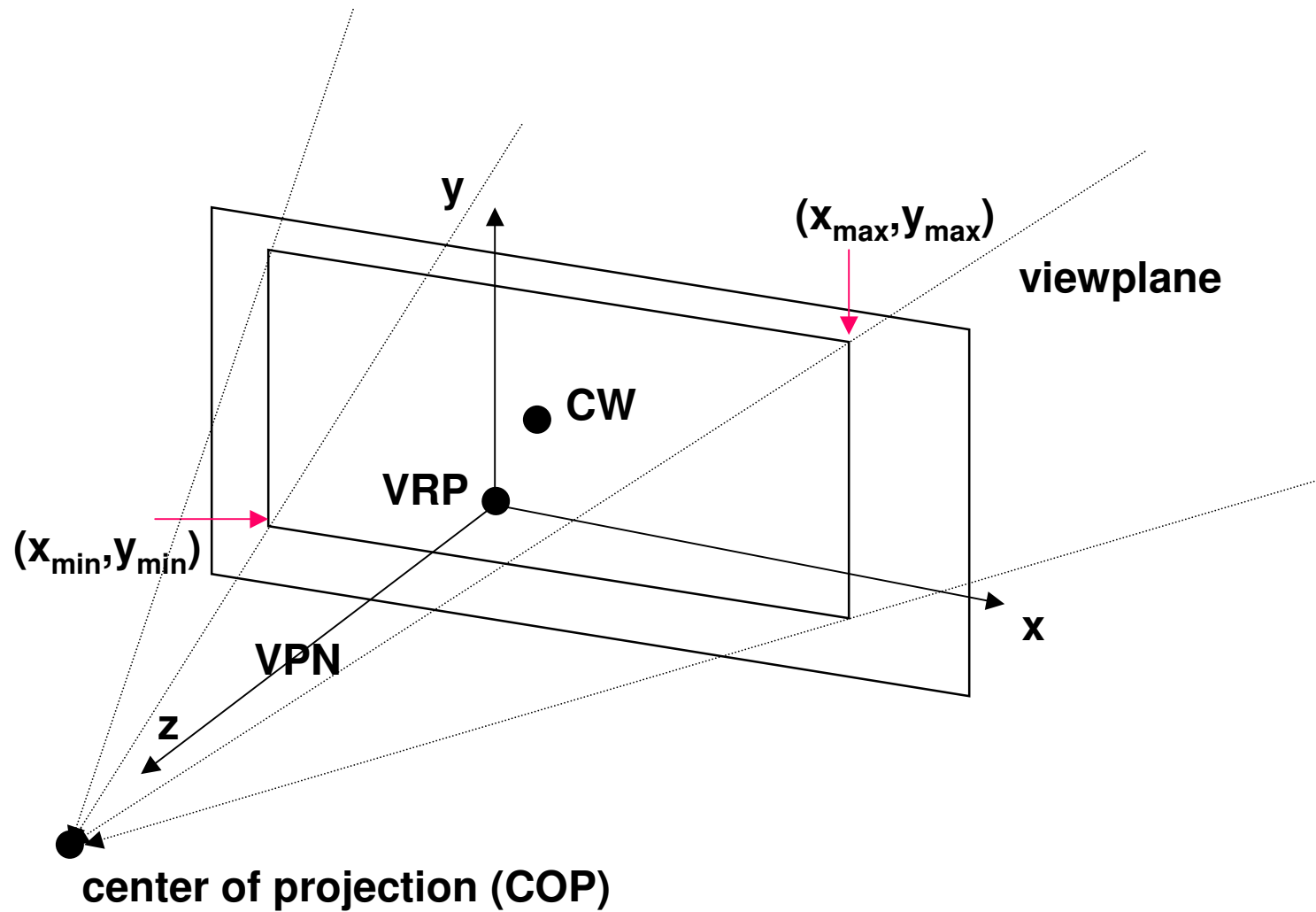

Defining camera position

- Camera center at VRP in world coordinates
- Orientation: given by VPN (perpendicular to camera back plane) and VUP vectors
- Open GL: using gluLookAt()
 - Specify eye point (VRP)
 - Specify “at” point, which together w/VRP defines VPN
 - Specify VUP vector

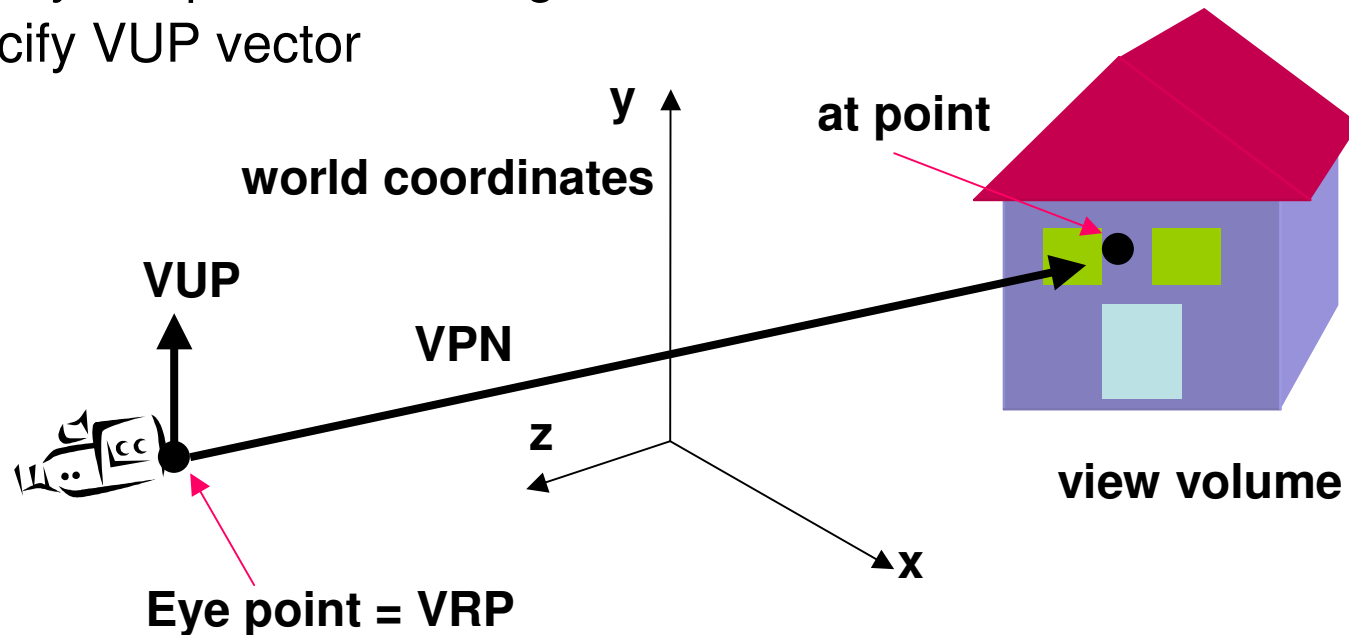

Clipping planes

View volume extents defined by near (front) and far (back) clipping planes

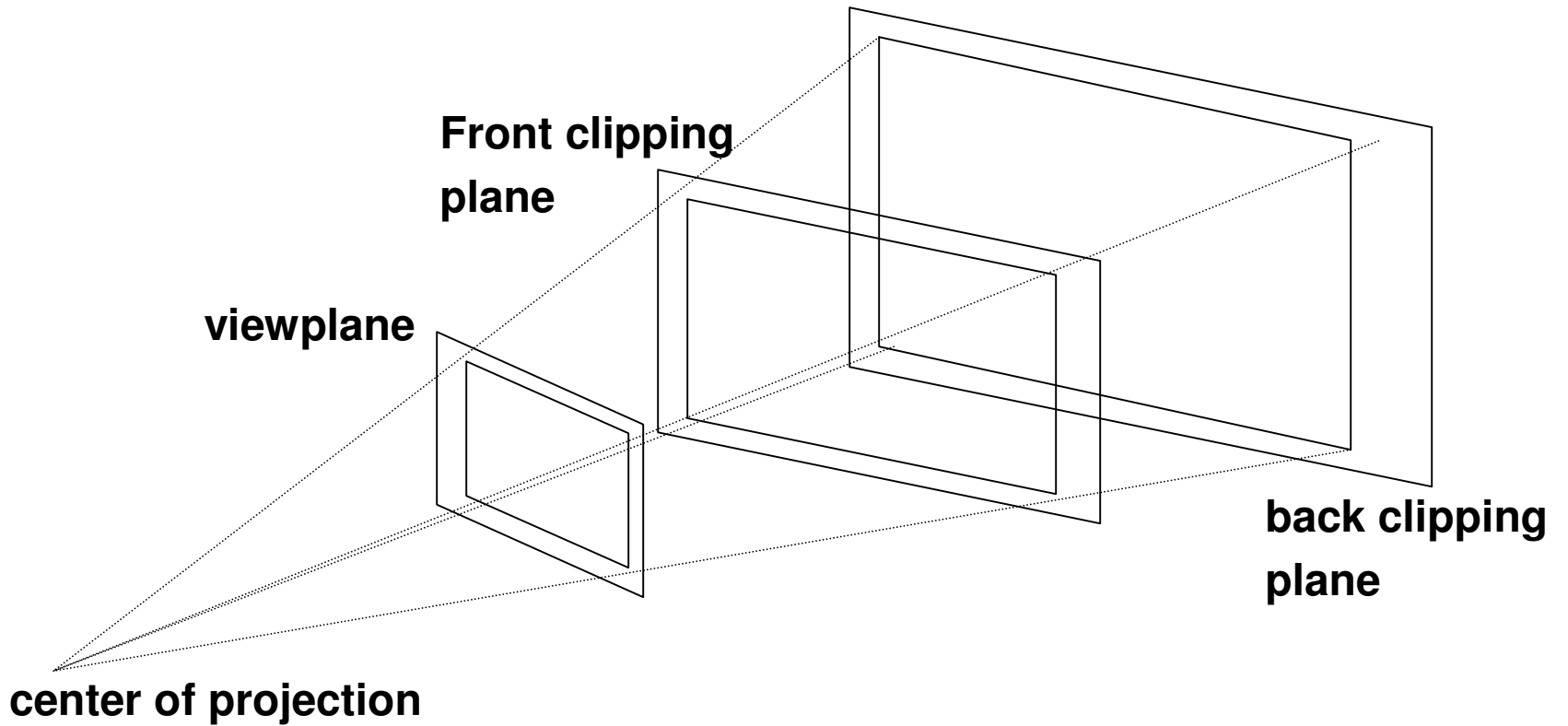

Perspective projection

- Parallel lines in world converge to vanishing point
- Possible to have a vanishing point per axis
- Vanishing point when window intersects axis
- Usually 1 or 2 vanishing points per projection

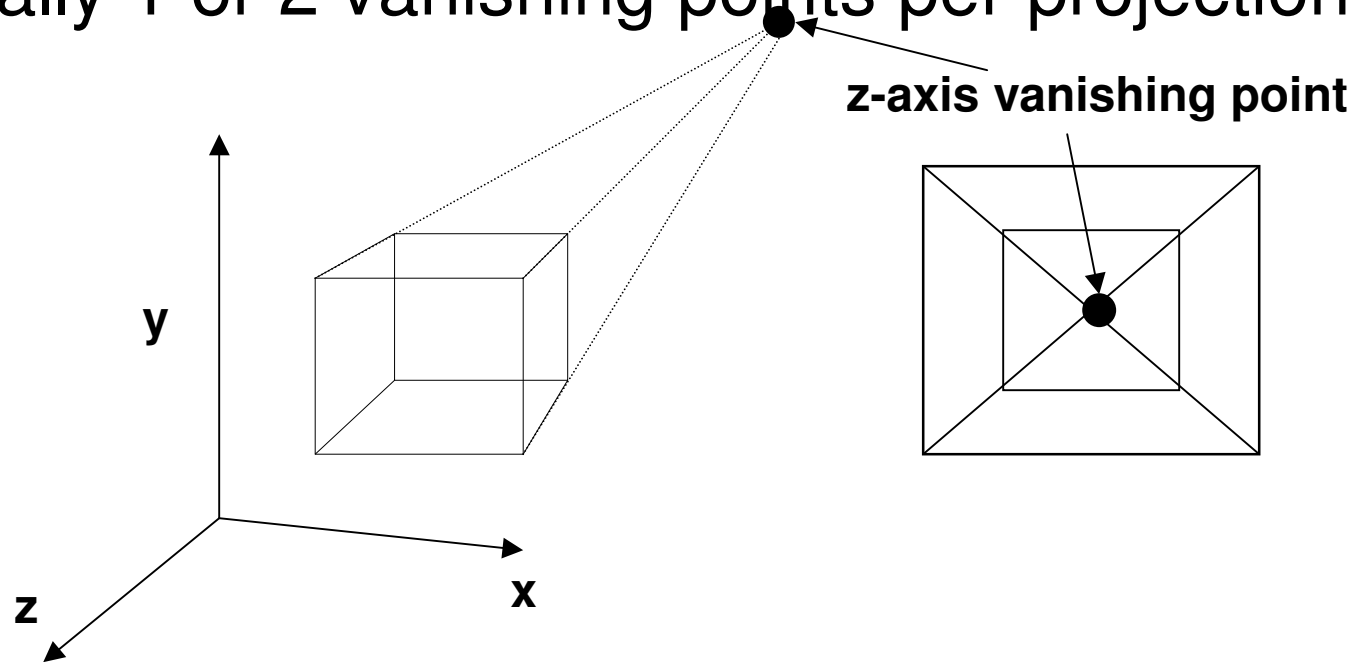

2-Point perspective

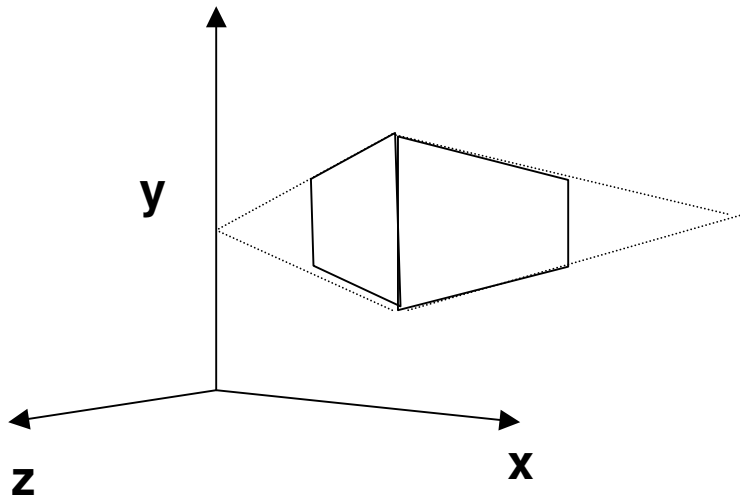

Perspective Projection & Homogenous coordinates

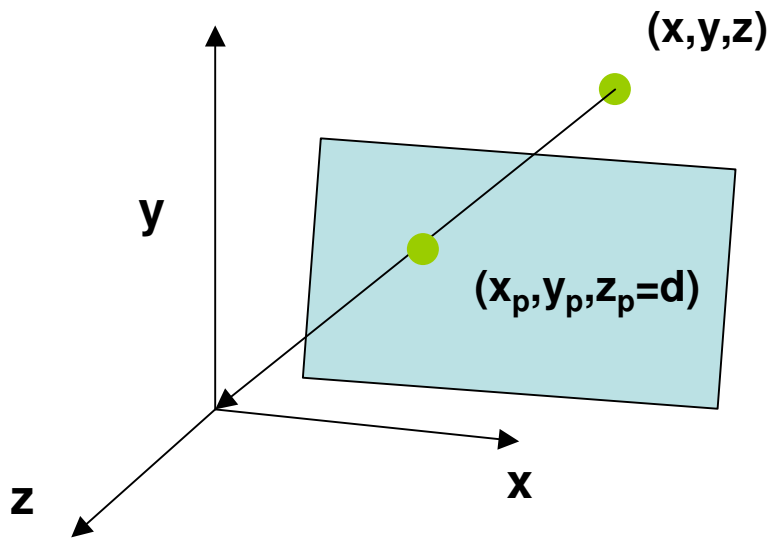

$$\begin{bmatrix} x \\ y \\ z \\ z/d \end{bmatrix} = \begin{bmatrix} 1 & 0 & 0 & 0 \\ 0 & 1 & 0 & 0 \\ 0 & 0 & 1 & 0 \\ 0 & 0 & 1/d & 0 \end{bmatrix} * \begin{bmatrix} x \\ y \\ z \\ 1 \end{bmatrix}$$

Now project to $w=1$ plane

Gives us our projected coordinates

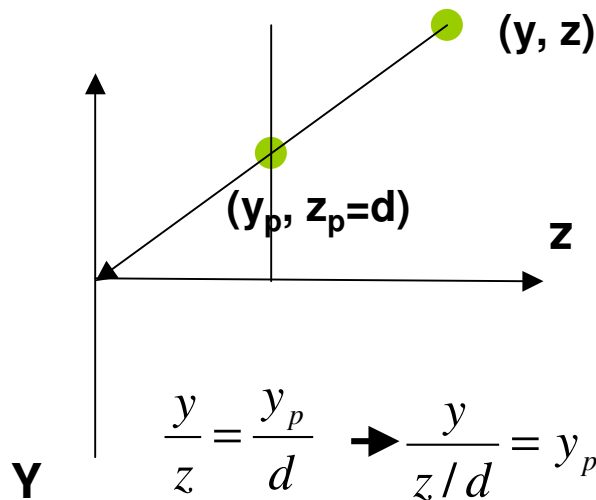
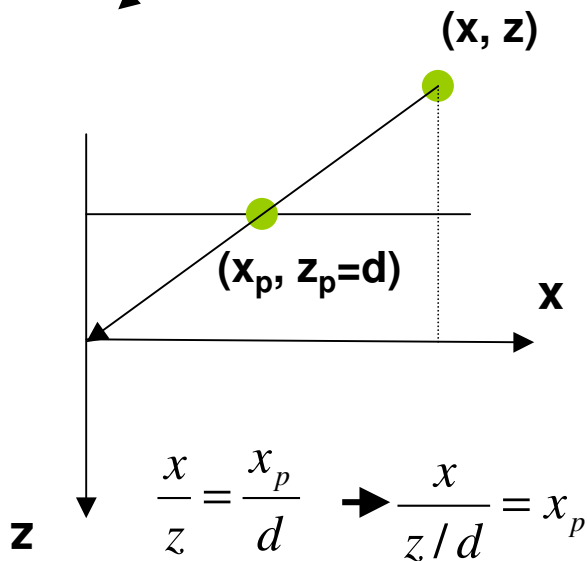

Parallel projections

- Projectors are parallel to direction of projection
- Center of Projection is at infinity (parallel projectors)
- Orthographic:
 - projection plane perpendicular to an axis
 - Parallel lines, distances and angles are preserved
- Oblique:
 - projection direction is NOT parallel to an axis
 - Parallel lines, distances along principal axis preserved

